

**CONDOMINIUM MAP OF
STONE CREEK CONDOMINIUMS**

**LOT 4, BLOCK 2 OF A REPLAT OF LOTS 4,5,9,10-A, AND TRACT G,
BLOCK 2; OFFICIAL PLAT-TOWN OF AVON
EAGLE COUNTY, COLORADO &
FINAL SUBDIVISION PLAT-AMENDMENT NO. 4
BENCHMARK AT BEAVER CREEK**

SHEET 1 OF 6

SURVEYOR'S CERTIFICATE:

I, James L. Wheat, a Registered Land Surveyor in the State of Colorado, do hereby certify that this Condominium Map of STONE CREEK CONDOMINIUMS was prepared by me or under my supervision and that the map accurately depicts the location and the horizontal and vertical measurements of the completed condominiums, to the best of my knowledge.

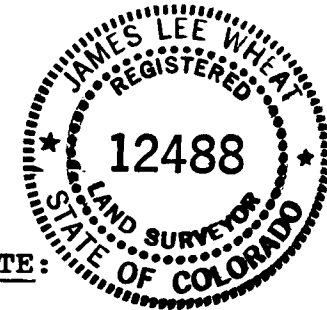

James L. Wheat
James L. Wheat
Registered Land Surveyor No. 12488

TOWN CERTIFICATE:

This Plat is approved by the Town Council of the Town of Avon, County of Eagle, Colorado, this 25th day of November, A.D. 1980, for filing with the Clerk and Recorder of the County of Eagle. Approval of this plat by the Town is a consent only and is not to be construed as an approval of the technical correctness of this plat or any documentation relating thereto.

WITNESS MY HAND AND SEAL OF THE TOWN OF AVON.

TOWN COUNCIL OF THE TOWN OF AVON

By: *Augusto V. Alpa*
Mayor

Attest: *Patricia J. Doyle*
Town Clerk

CLERK AND RECORDER'S CERTIFICATE: 212018

This Plat was filed for record in the Office of the Clerk and Recorder at 2:00 o'clock, P.M., December 31, 1980, and is duly recorded in Plat Book 315, Page No. 644.
Drawn 15" Fee \$60.00 pd.

By: *Kathleen P. Day* Deputy
Sherrille Phillips Clerk and Recorder

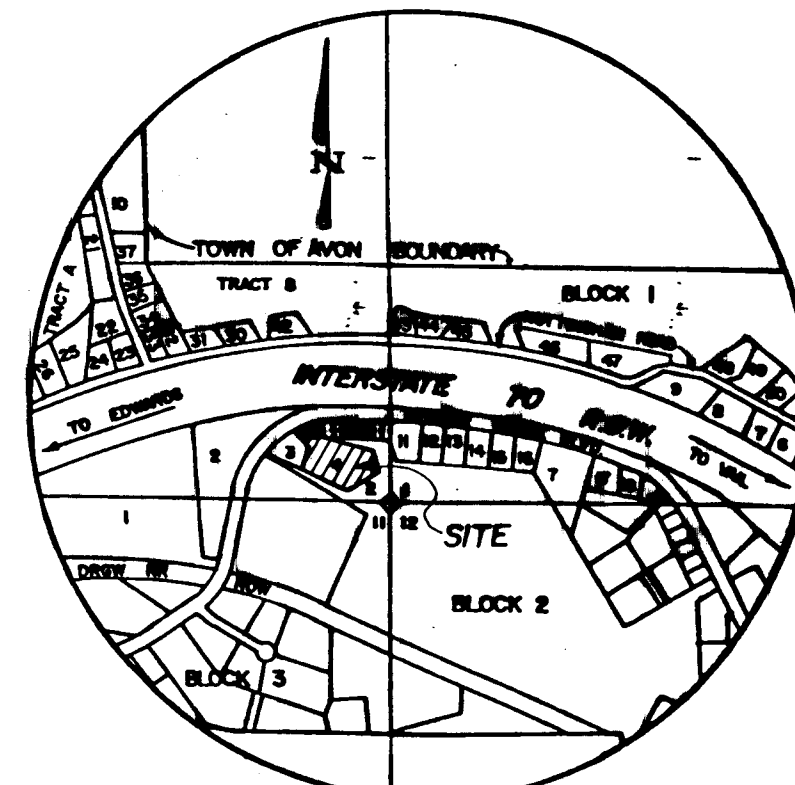
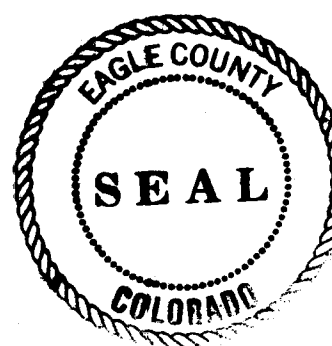

VICINITY MAP
SCALE: 1" = 100'

NOTE:
UNITS 101,102,103,104,105,106,107,201,202,
203,204,205,206, AND 207, CLUSTER A,
UNITS 108,208, AND 308, CLUSTER B, AND
UNITS 109,110,111,112,113,114,115, 209,210,
211,212,213,214, AND 215 CLUSTER C, WILL
NOT BE USED FOR TIME-SHARING.

OWNER'S CERTIFICATE:

The undersigned, being the owner of the following described parcel of land:

Lot 4, Block 2, Benchmark at Beaver Creek, Town of Avon, Eagle County, Colorado;

does hereby certify that the condominium map of STONE CREEK CONDOMINIUMS is filed in conjunction with the condominium declaration for STONE CREEK CONDOMINIUMS and that easements, rights of way and other interests in land are created, dedicated and platted as shown hereon and as defined in the Condominium Declaration recorded AUGUST 1, 1980, in Book 306, Pages 403 inclusive of the records of the Eagle County Clerk and Recorder.

STONE CREEK CONDOMINIUMS, INC.
32107 W. Lindero Canyon Rd., Suite 119
Westlake Village, Calif. 91361

By: *Robert L. Jackson*
Robert L. Jackson

STATE OF COLORADO)
COUNTY OF EAGLE) ss

The foregoing dedication was acknowledged before me this 20th day of November, A.D. 1980., by Robert L. Jackson of Stone Creek Condominiums, Inc.

My commission expires Sept 30 1981.

Witness my hand and seal.

Claudia J. Nelson
Notary Public

CONDOMINIUM MAP OF STONE CREEK CONDOMINIUMS

BEAVER CREEK BLVD. (80')
 $R=498.40'$
 $N 63^{\circ}12'14" E$
 $C=36.67'$

SHEET 2 OF 6

LOT 3

LOT 5

TRACT G

LOT 4, BLOCK 2

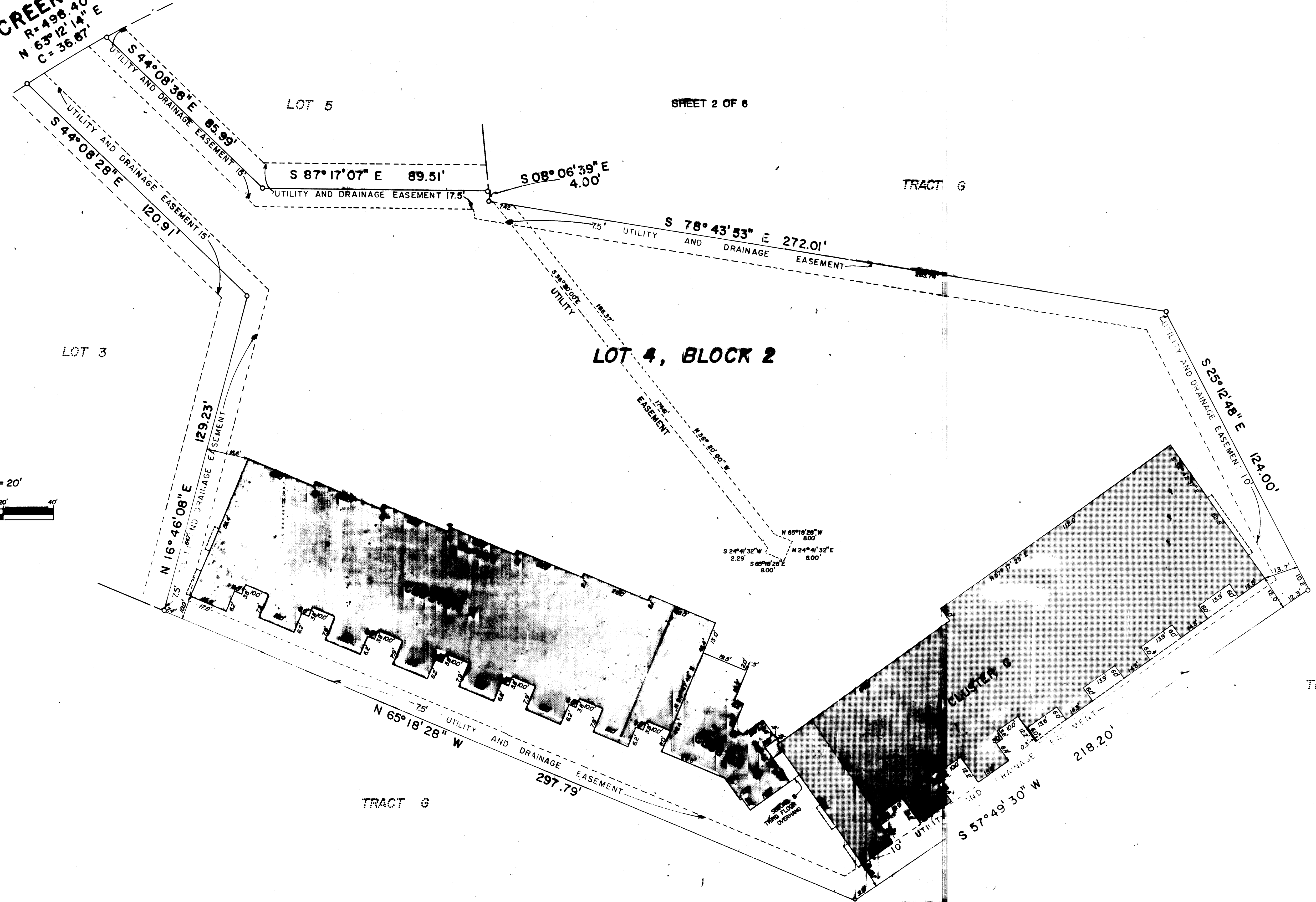
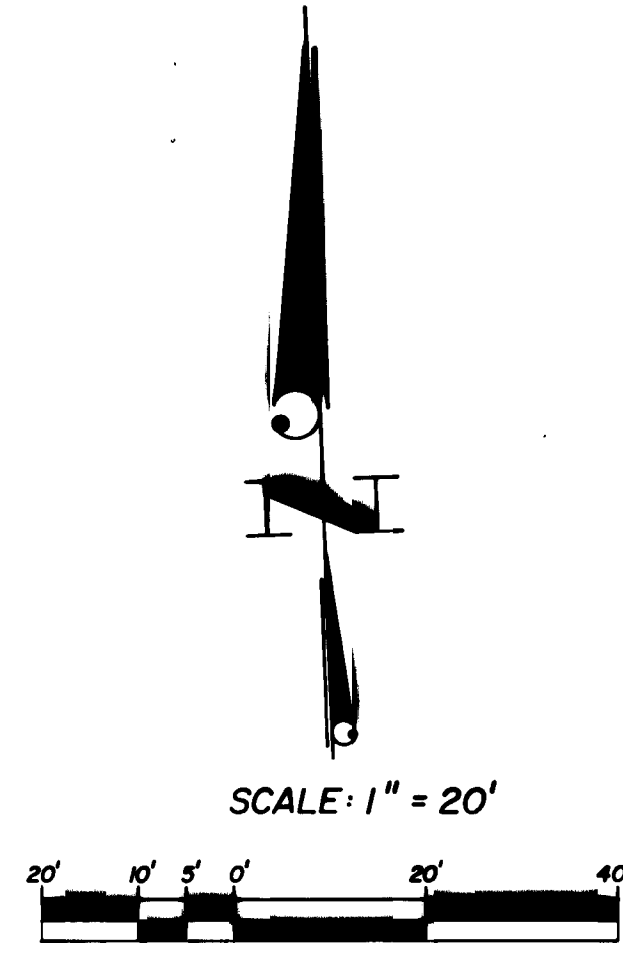

TRACT G

ELEVATION: MRLS-I.A.I-INV. 7422.31 E
 RIM ELEV. 7429.86

CONDOMINIUM MAP OF STONE CREEK CONDOMINIUMS

SHEET 3 OF 6

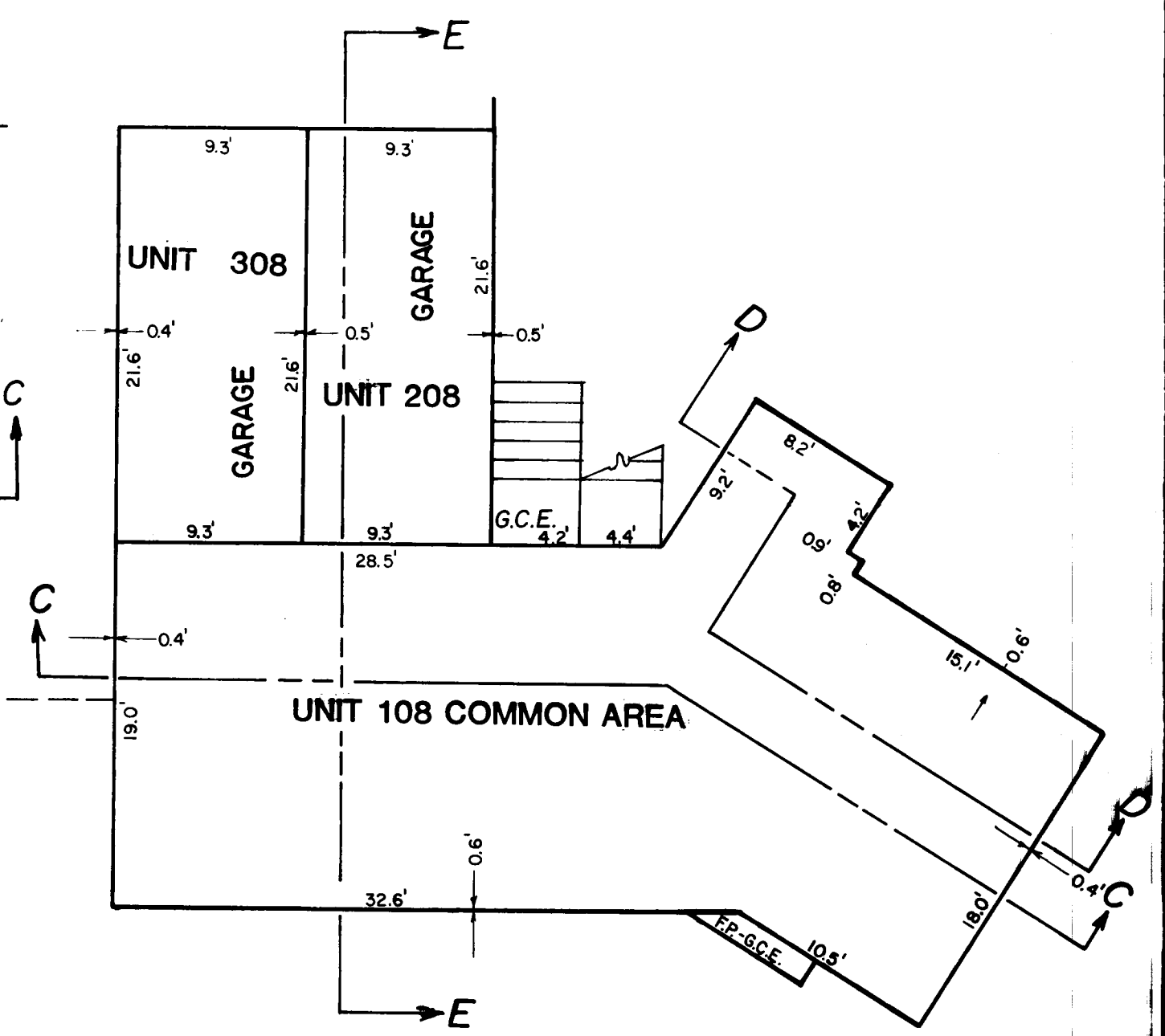
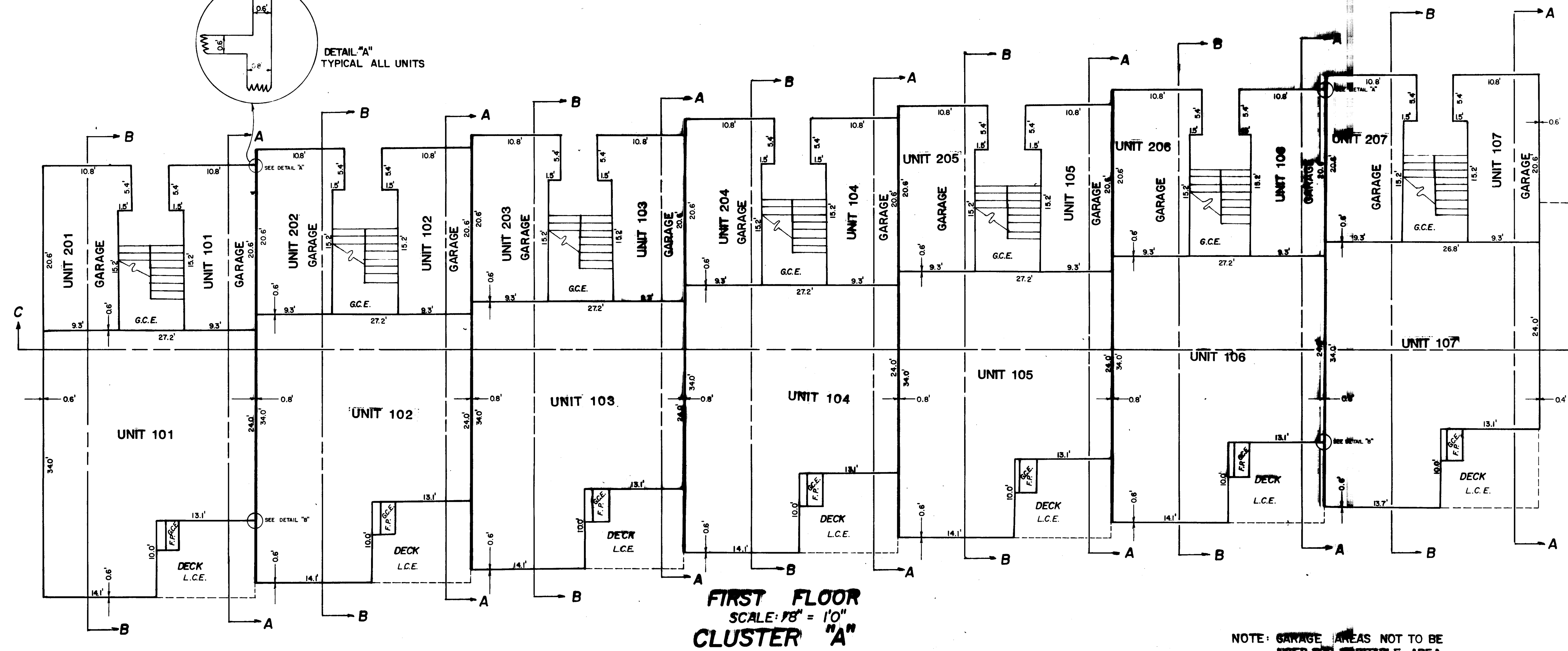
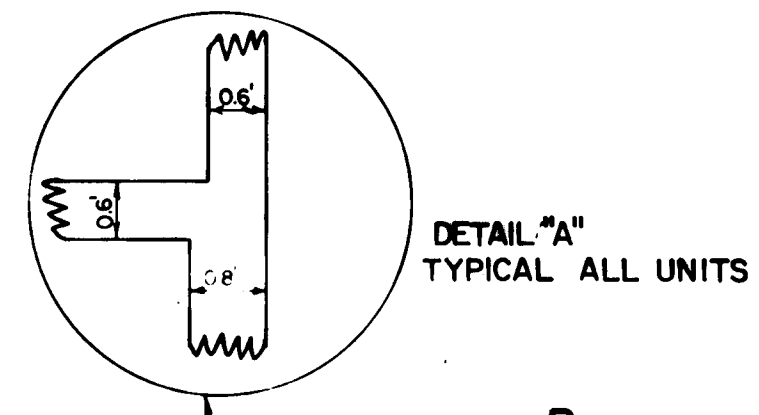
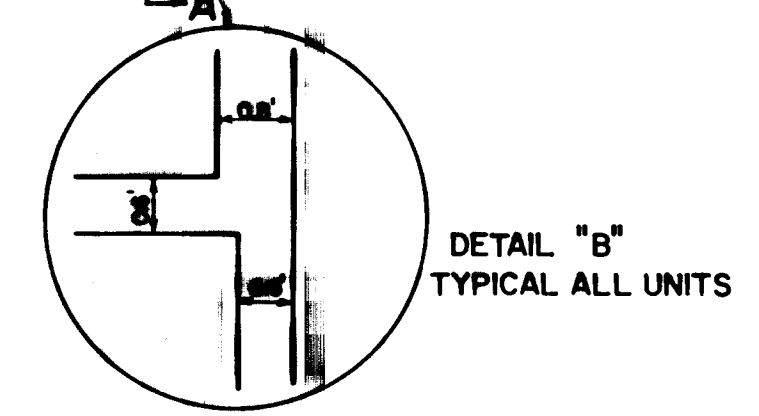
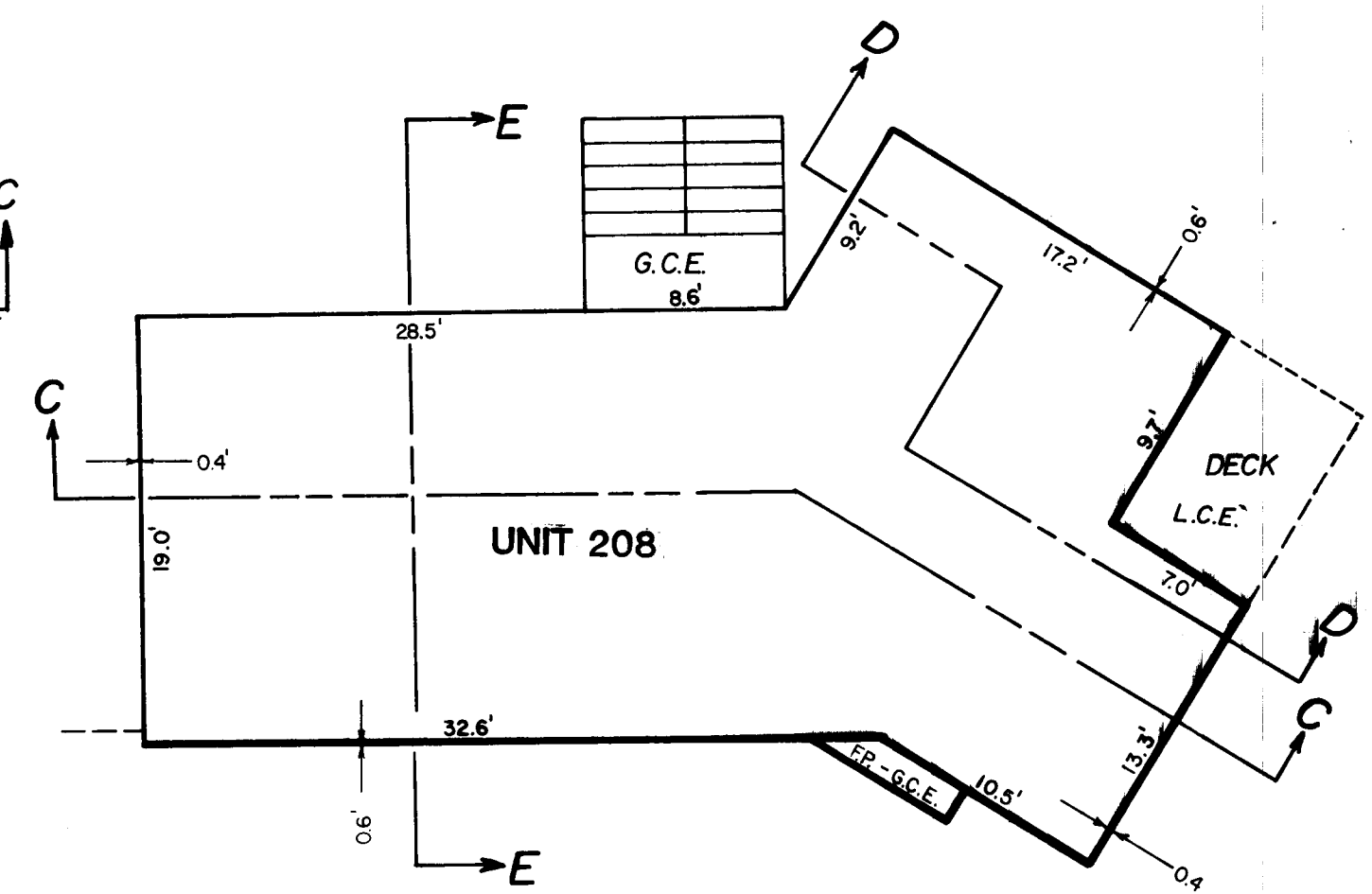
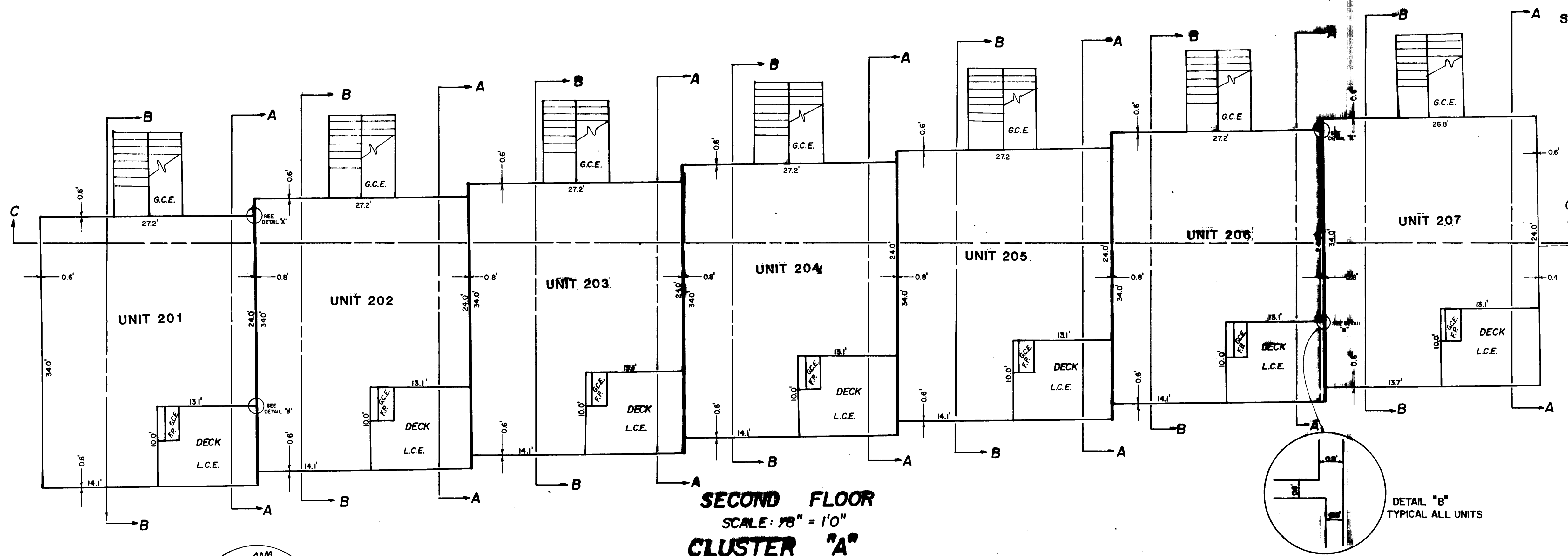

NOTE: GARAGE AREAS NOT TO BE
USED FOR HABITABLE AREA.

CONDOMINIUM MAP OF STONE CREEK CONDOMINIUMS

SHEET 4 OF 6

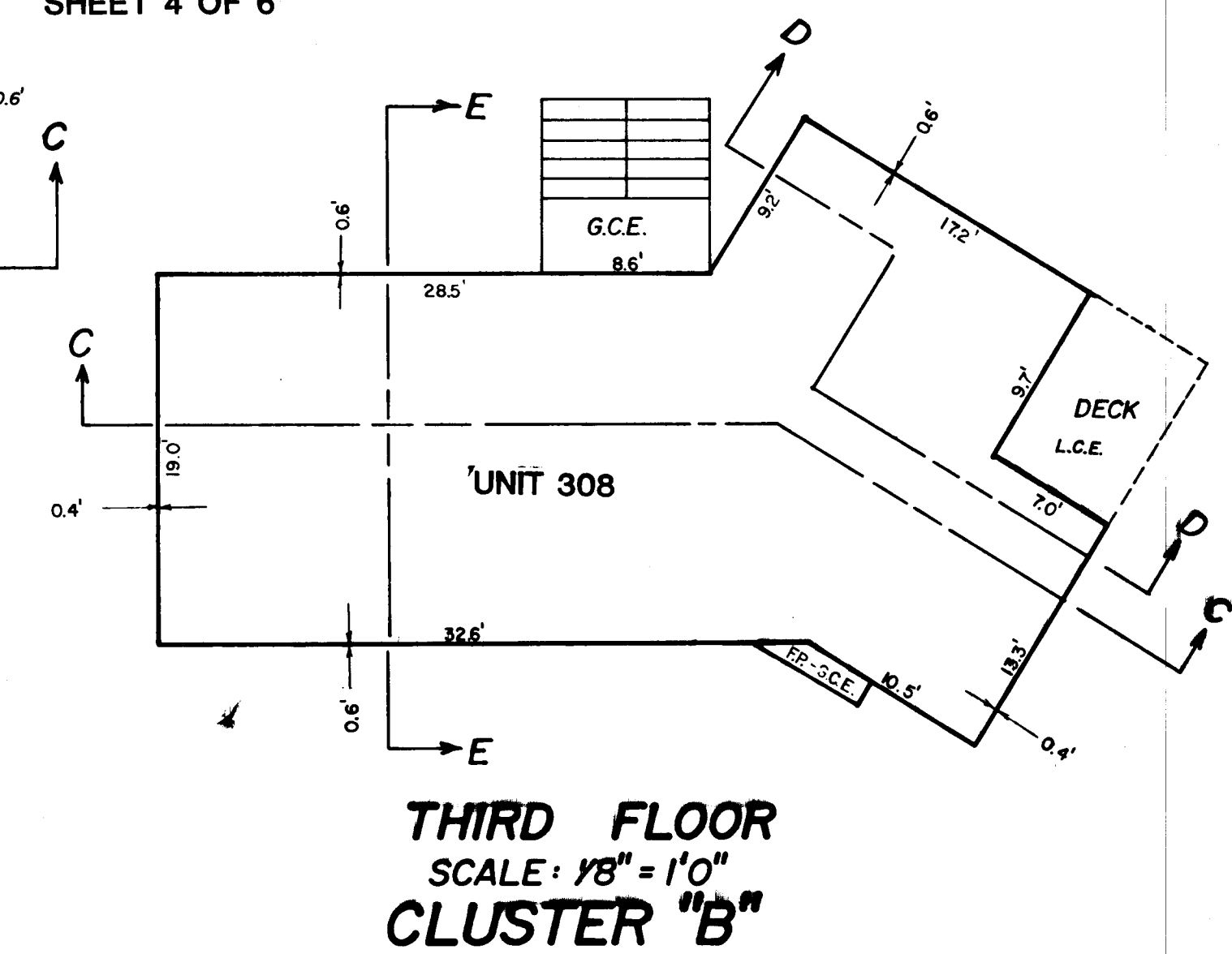
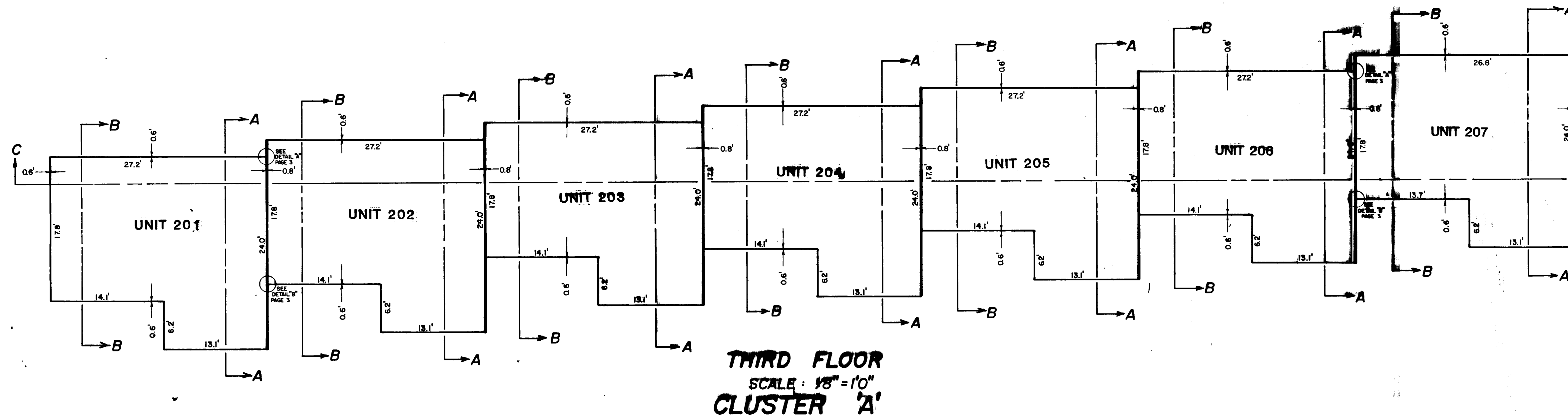

FIREPLACE DETAILS
SCALE: 1/4" = 1'



ONE BEDROOM UNIT
FIRST FLOOR
CLUSTER A & C

TWO BEDROOM UNIT
FIRST & SECOND FLOOR
CLUSTER C



THREE BEDROOM UNIT
SECOND FLOOR
CLUSTER A & C

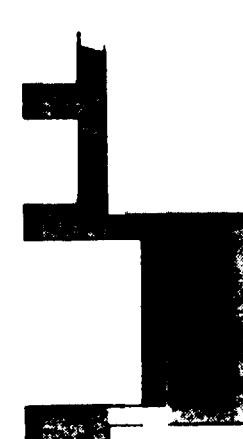

THREE BEDROOM UNIT
THIRD FLOOR
CLUSTER A & C



FIREPLACES - G.C.E.

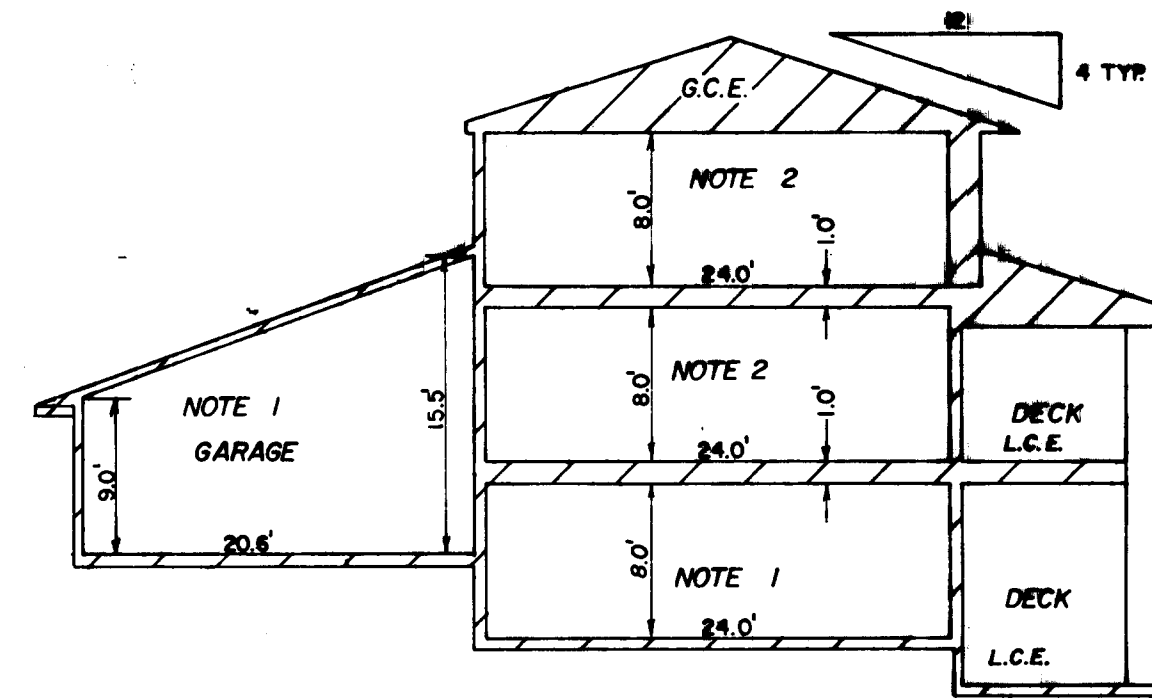

**SECTION A-A
SCALE: 1" = 10.0'
CLUSTER 'A'**

NOTE 1 - UNITS 101, 102, 103, 104, 105, 106, & 107
NOTE 2 - UNITS 201, 202, 203, 204, 205, 206, & 207

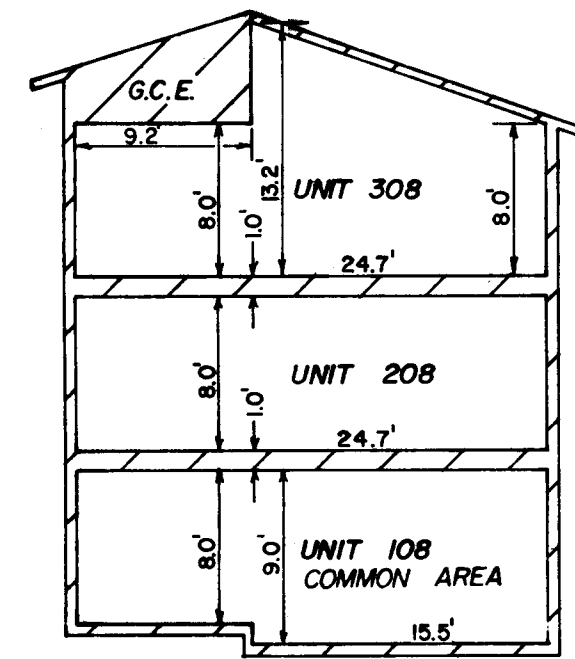

**SECTION D-D
SCALE: 1" = 10.0'
CLUSTER 'B'**

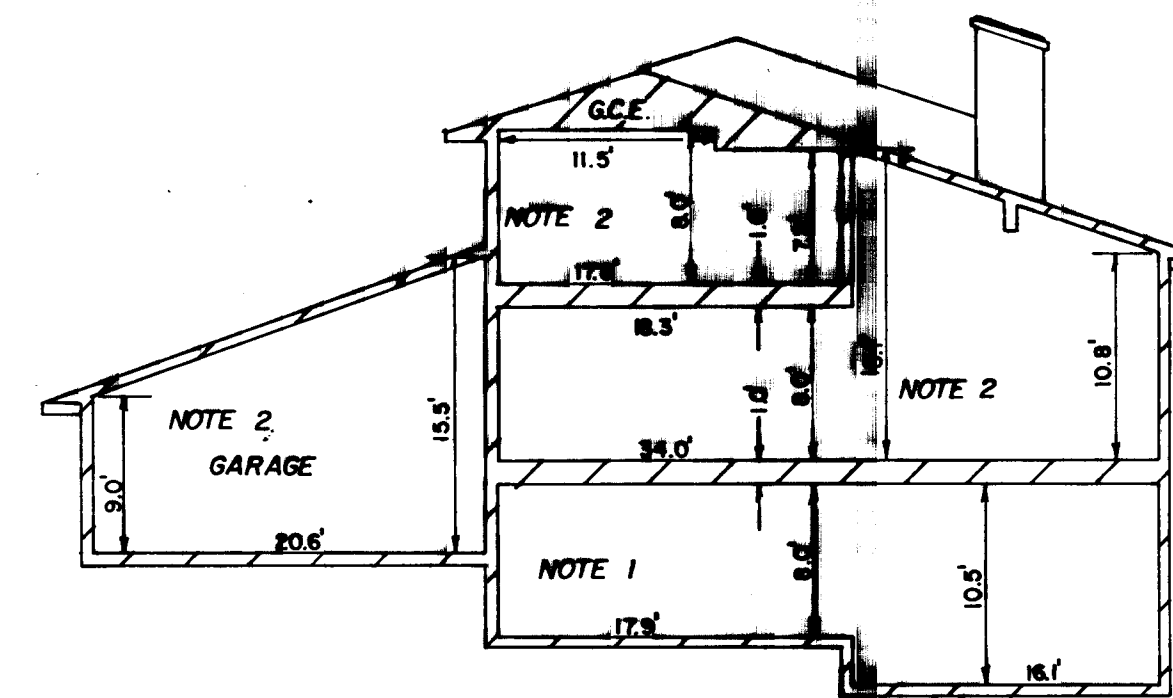

**SECTION B-B
SCALE: 1" = 10.0'
CLUSTER 'A'**

NOTE 1 - UNITS 101, 102, 103, 104, 105, 106, & 107
NOTE 2 - UNITS 201, 202, 203, 204, 205, 206, & 207

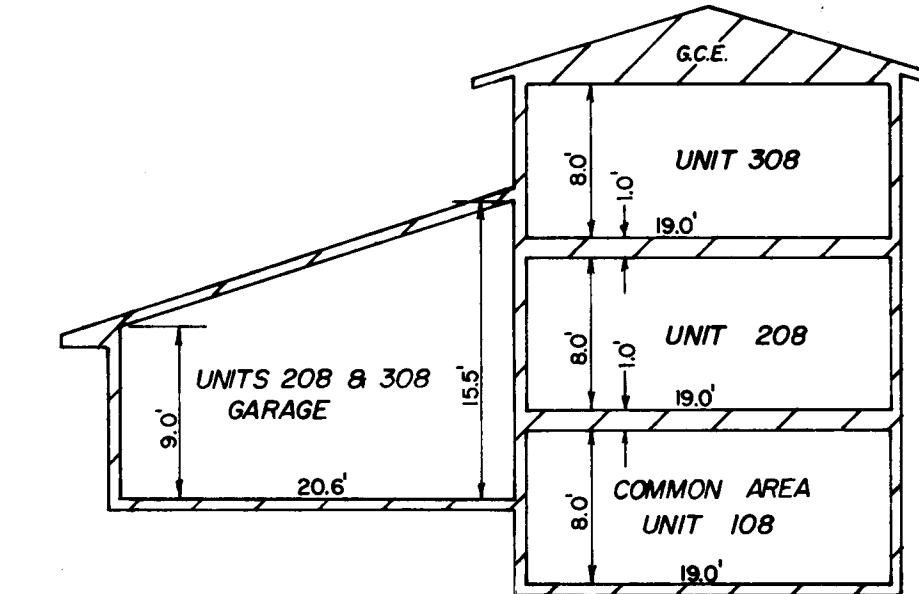

**SECTION E-E
SCALE: 1" = 10.0'
CLUSTER 'B'**

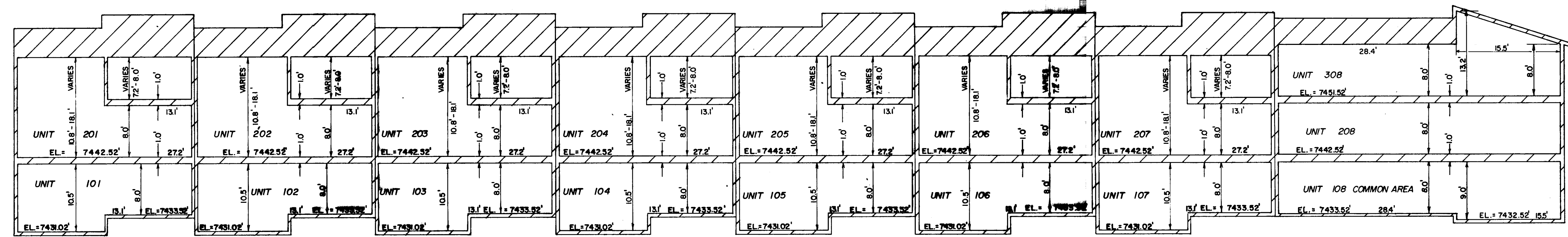

**SECTION C-C
SCALE: 1" = 10.0'
CLUSTER 'A'**

**SECTION C-C
SCALE: 1" = 10.0'
CLUSTER 'B'**

NOTE: ALL CROSS-HATCHED AREAS ARE G.C.E.

CONDOMINIUM MAP OF STONE CREEK CONDOMINIUMS

SHEET 5 OF 6

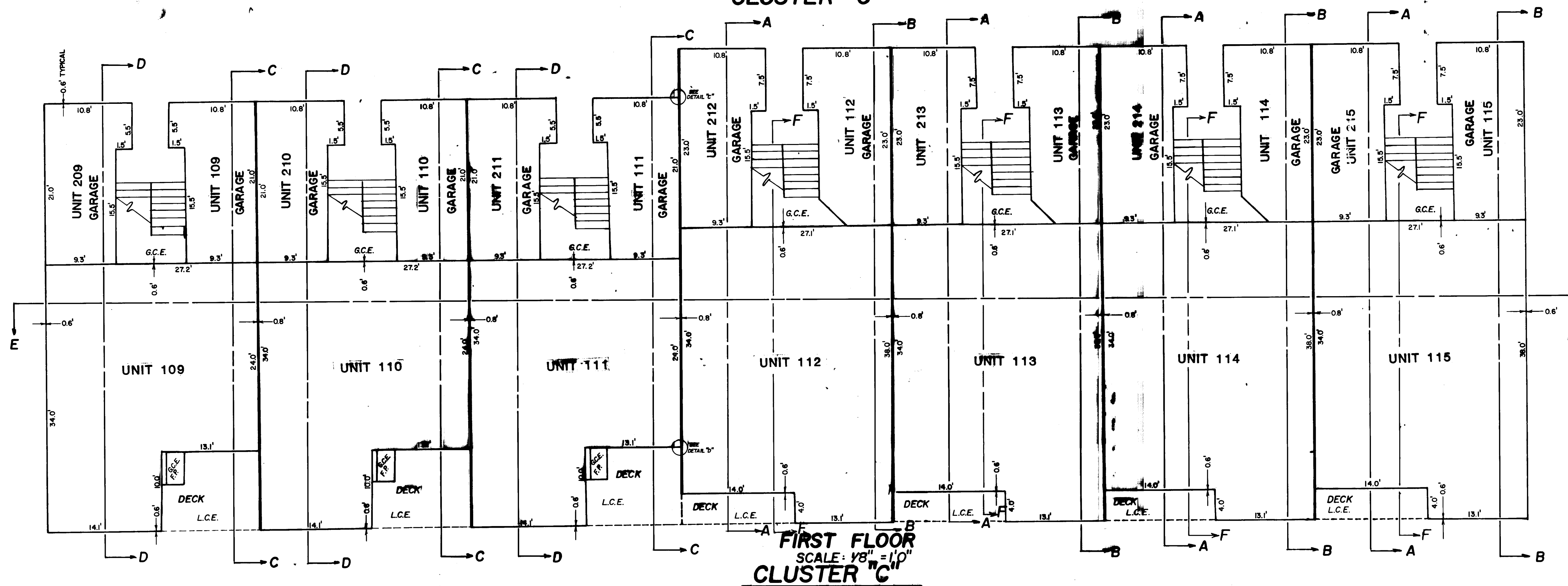
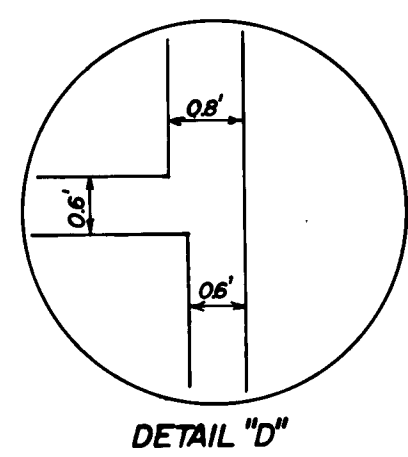
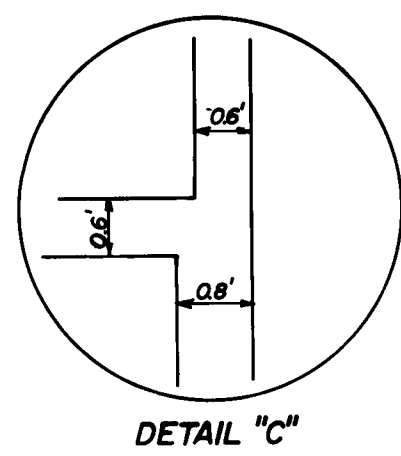
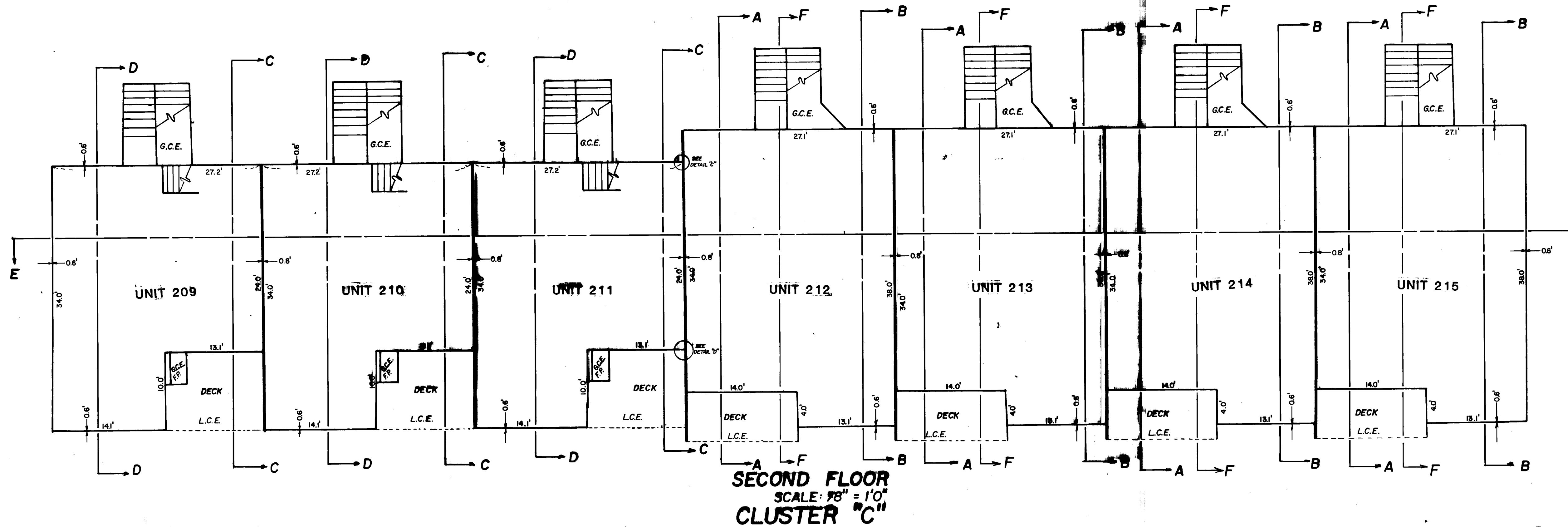

NOTE: GARAGE AREAS NOT TO BE
USED FOR HABITABLE AREA

**CONDOMINIUM MAP OF
STONE CREEK CONDOMINIUMS**

SHEET 6 OF 6'

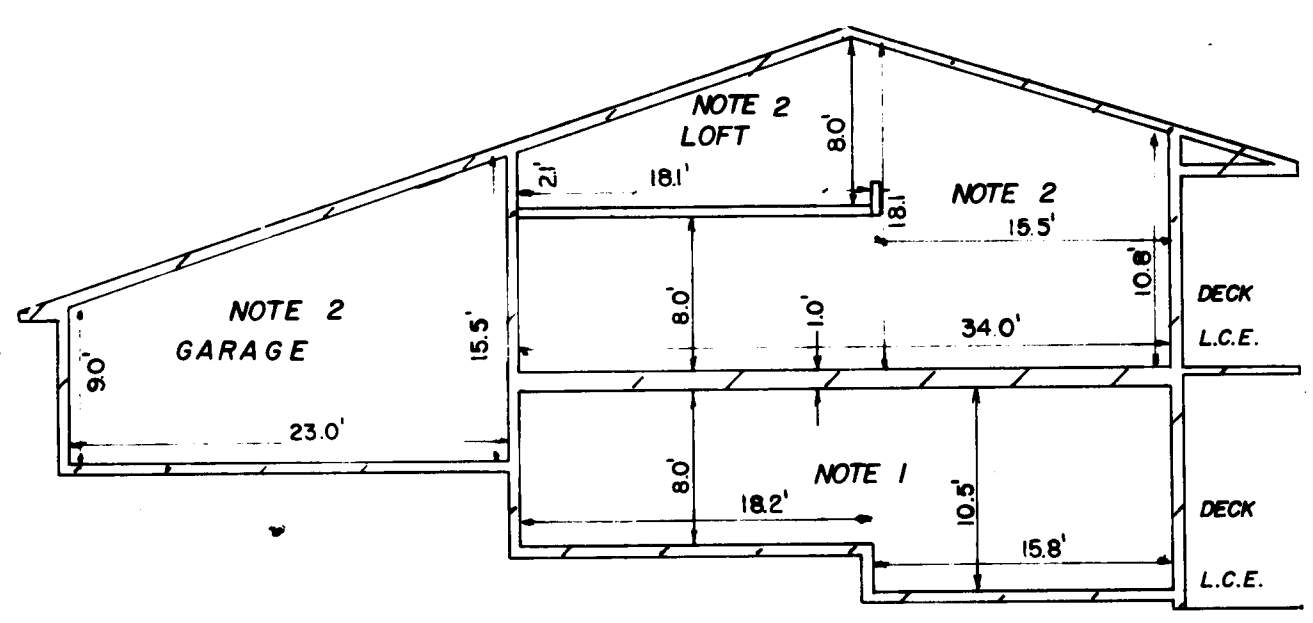
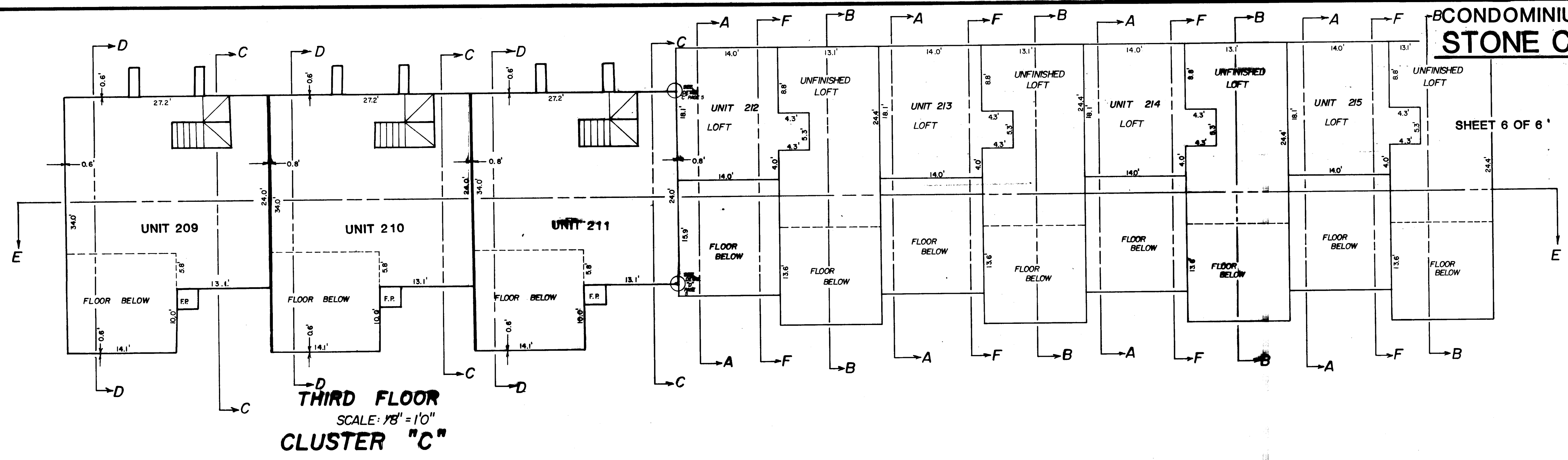

**SECTION A-A
SCALE: 1" = 10.0'**

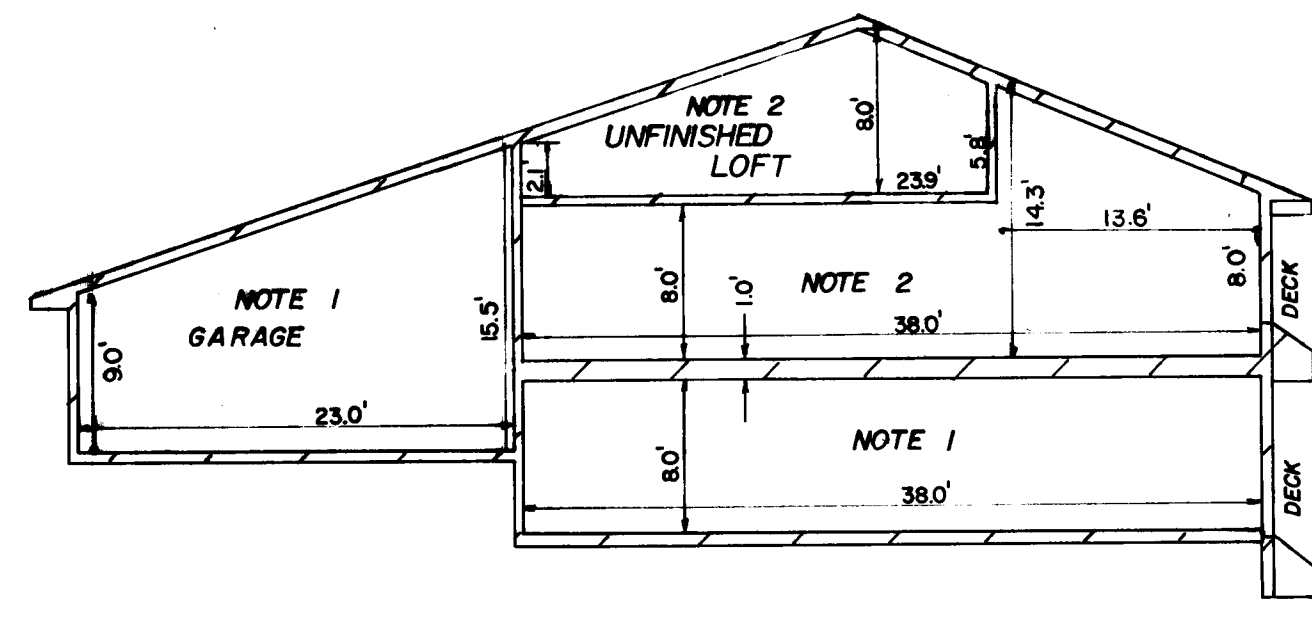

**SECTION B-B
SCALE: 1" = 10.0'**

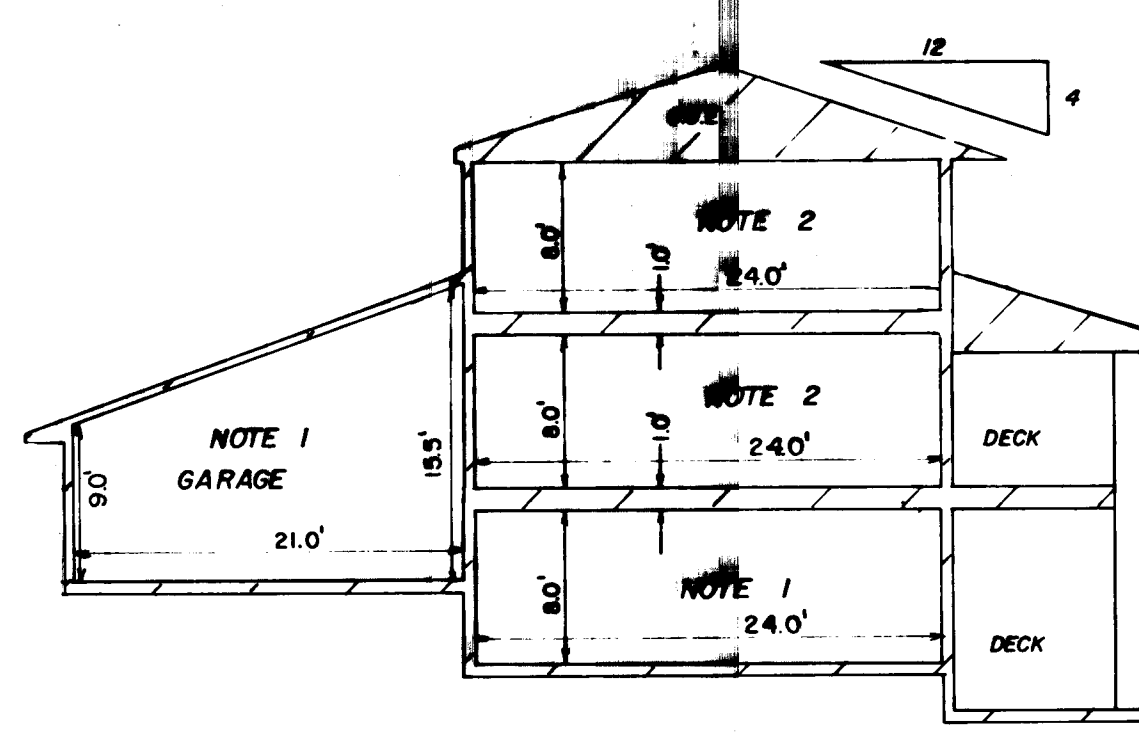

**SECTION C-C
SCALE: 1" = 10.0'**

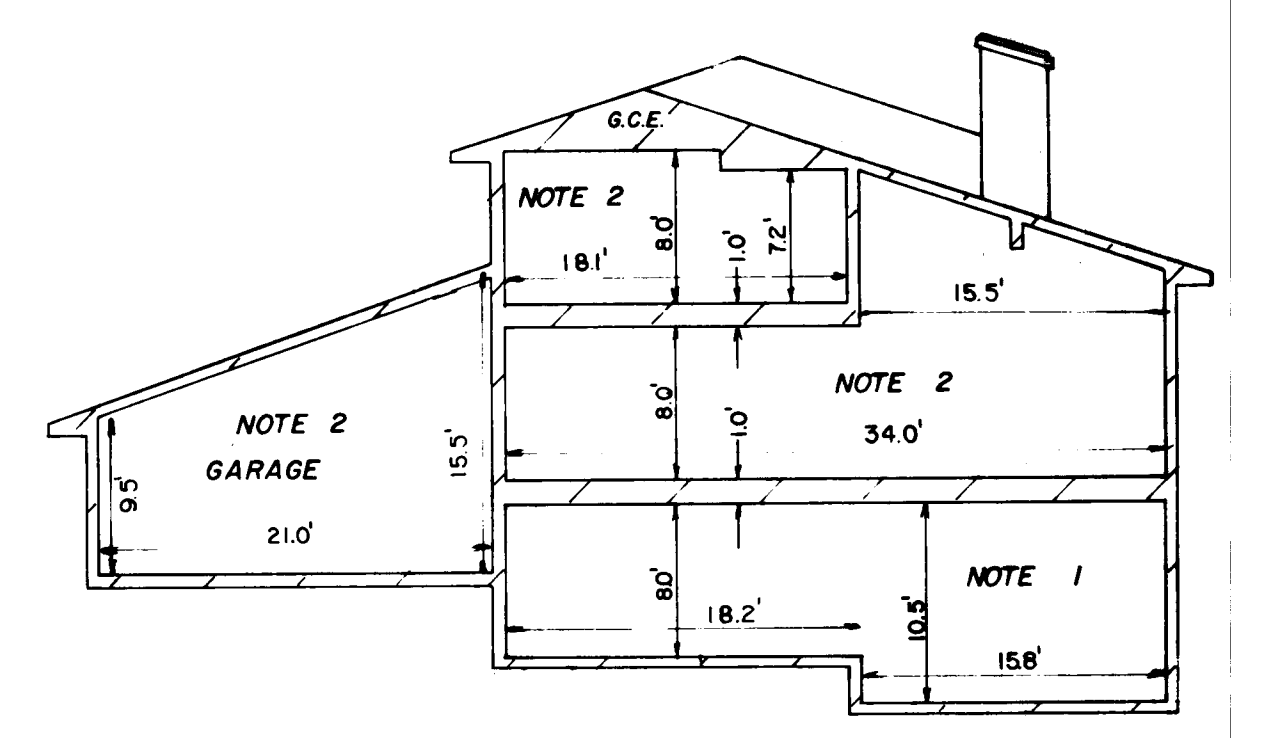

**SECTION D-D
SCALE: 1" = 10.0'**

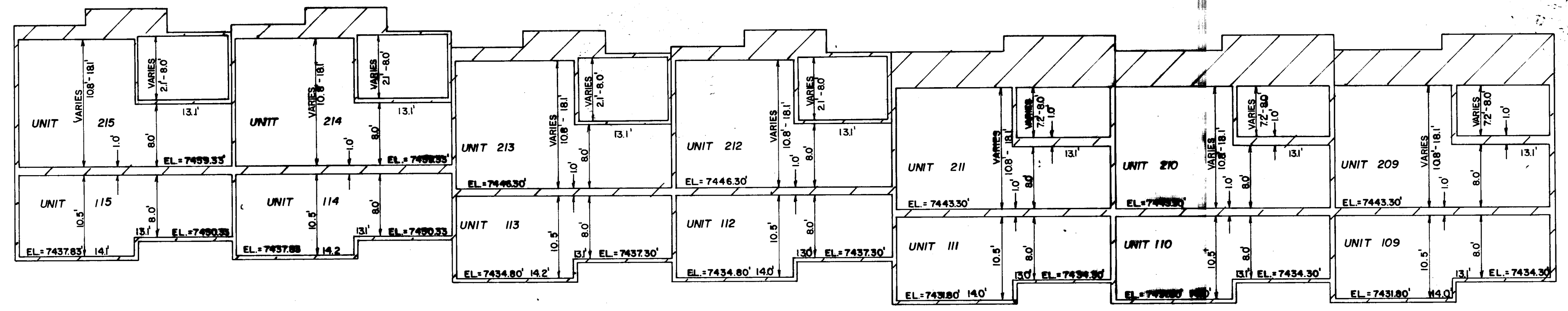

NOTE 1 - UNITS 109, 110, 111, 112, 113, 114, & 115
NOTE 2 - UNITS 209, 210, 211, 212, 213, 214, & 215

**SECTION E-E
SCALE: 1" = 10.0'
CLUSTER "C"**

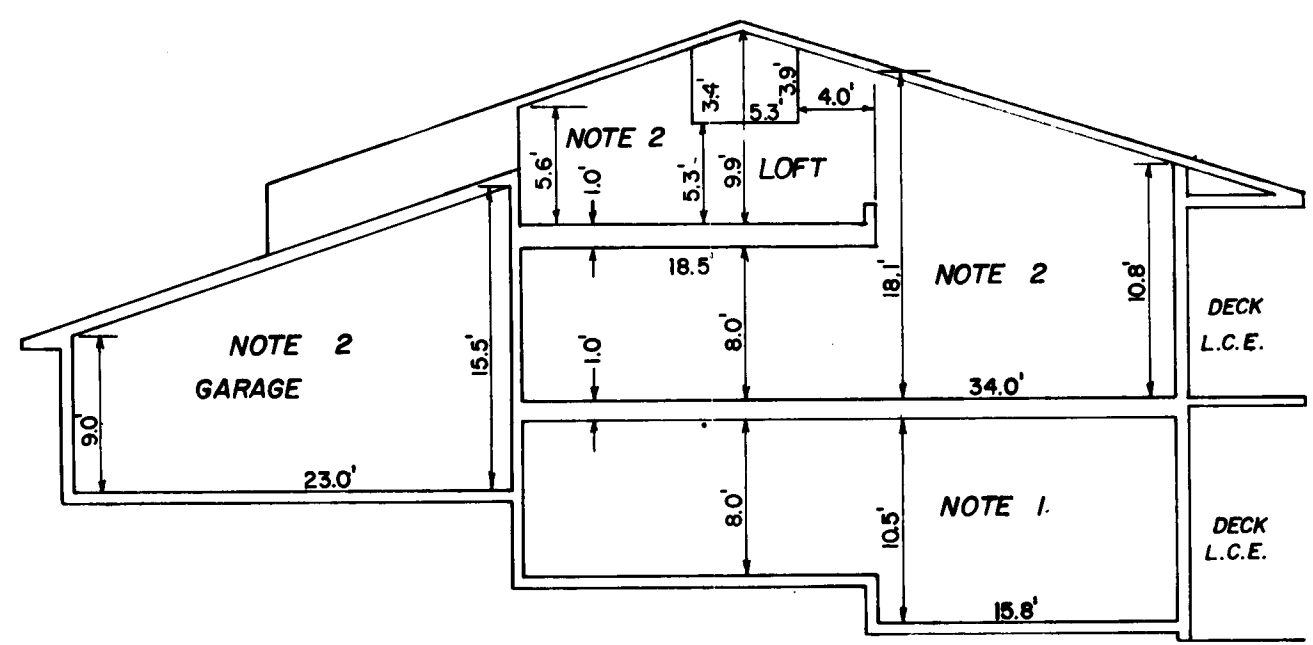

**SECTION F-F
SCALE: 1" = 10.0'**